



**AIR OPERATED
DOUBLE
DIAPHRAGM
PUMPS**



ISO 9001: 2008
ISO 14001: 2004

pricepumps.co.in

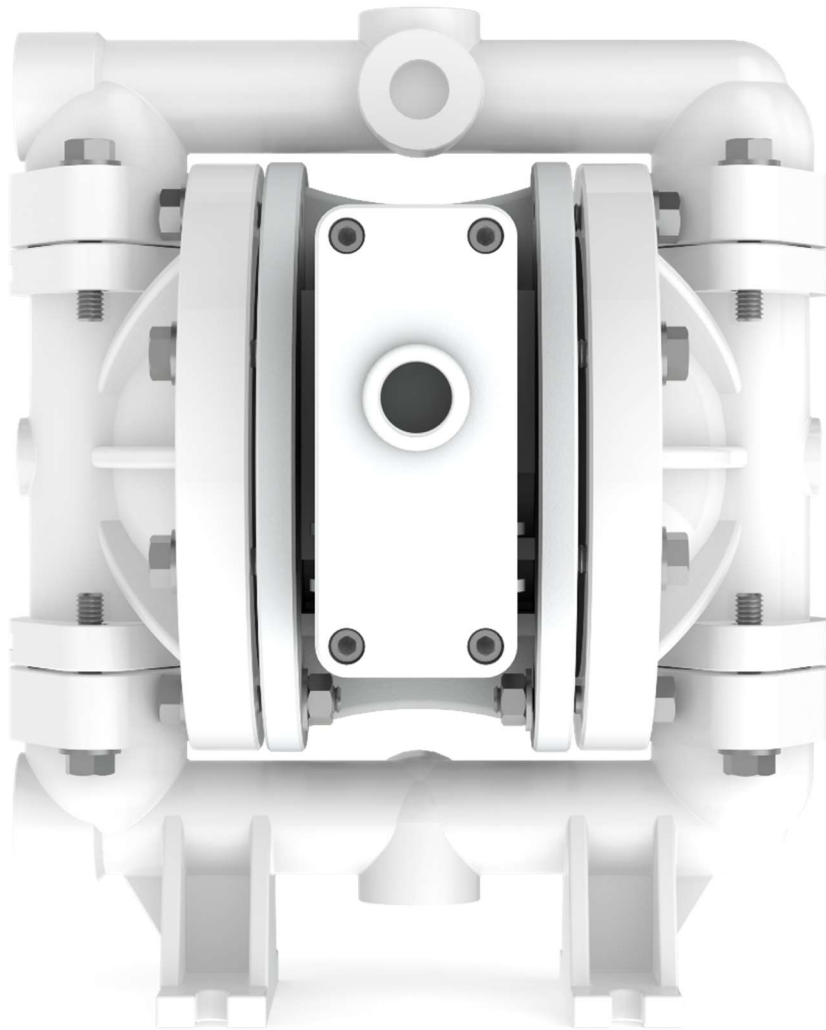

**1/2" POLYPROPYLENE PUMP
AOD 150 PF PKGP/SAN/TF/P/N**

pricepumps.co.in



AIR OPERATED DOUBLE DIAPHRAGM PUMPS



ISO 9001: 2008
ISO 14001: 2004

pricepumps.co.in

SECTION 1- LEGEND

½” POLYPROPYLENE PUMP

AOD 150/PKGP/SAN/TF/P/N

MODEL: AOD 150 PF POLYPROPYLENE

13mm (½”) Pump

Maximum Flow Rate: 56 Lpm (14.8 gpm)

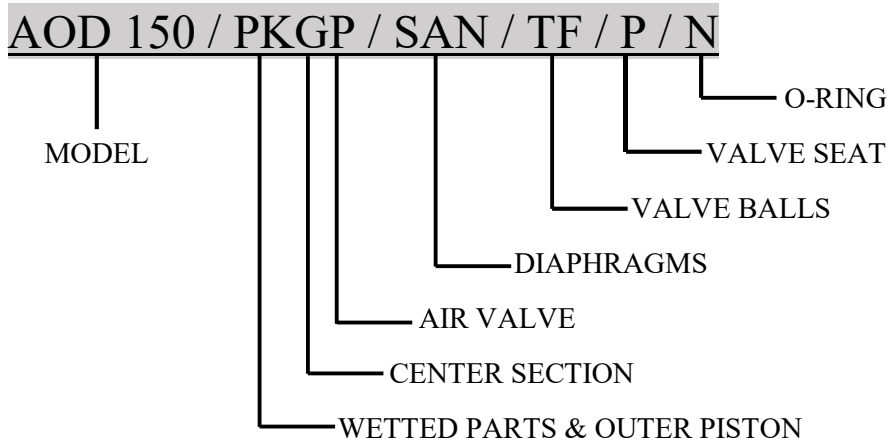

MATERIAL CODES

MODEL
AOD 150 = ½” PUMP

AIR VALVE
P = POLYPROPYLENE

VALVE BALL
TF = TEFLON

WETTED PARTS & OUTER PISTON
PK = POLYPROPYLENE/
POLYVINYLIDENEFLUORIDE

DIAPHRAGMS
SAN = SANTOPRENE

VALVE SEAT
P = POLYPROPYLENE

CENTER SECTION
G = GLASS FILLED
POLYPROPYLENE

VALVE SEAT O-RING
N = NEOPRENE



AIR OPERATED DOUBLE DIAPHRAGM PUMPS



ISO 9001: 2008
ISO 14001: 2004

pricepumps.co.in

SECTION 2 – SPARE PART LIST

½” POLYPROPYLENE PUMP

AOD 150/PKGP/SAN/TF/P/N

SR NO.	DISCRIPTION	PART NO.	QTY.
1	LIQUID CHAMBER	15-1001-20	2
2	SUCTION MANIFOLD	15-1021-20	2
3	DISCHARGE MANIFOLD	15-1031-20	2
4	SEAT O RING	15-3101-51	4
5	MANIFOLD O RING	15-3111-51	4
6	NRV BALL	15-1041-55	4
7	BALL SEAT	15-1061-20	4
8	BALL CAGE	15-1091-20	4
9	HOLDING PLATE	15-1111-01	2
10	LOCK NUT	15-1131-21	2
11	DIAPHRAGM	15-2041-58	2
12	BACK UP DIAPHRAGM	N/A	N/A
13	CENTER BLOCK	15-1301-23	1
14	REDUCER	15-1376-21	1
15	CENTER BLOCK O RING	15-3155-56	2
16	MAIN SHAFT	15-1341-03	1
17	PILOT SHAFT	15-1451-03	1
18	PILOT BUSH	15-1471-07	1
19	PILOT SHAFT O RING	15-3176-56	4
20	PILOT BUSH O RING	15-3161-51	4
21	PILOT SHAFT LOCK O RING	40-3181-51	2
22	PILOT BUSH CIRCLIP	15-1496-61	2



AIR OPERATED DOUBLE DIAPHRAGM PUMPS



ISO 9001: 2008
ISO 14001: 2004

pricepumps.co.in

SECTION 2 – SPARE PART LIST (CONTINUED...)

½” POLYPROPYLENE PUMP

AOD 150/PKGP/SAN/TF/P/N

SR NO.	DISCRIPTION	PART NO.	QTY.
23	PISTON BLOCK	15-1501-20	1
24	PISTON	15-1521-69	1
25	PISTON O RING BIG	15-3201-51	1
26	PISTON O RING SMALL	15-3221-51	5
27	PISTON RING BIG	15-3241-68	1
28	PISTON RING SMALL	15-3246-68	5
29	P B CAP	15-1571-20	1
30	P B CAP O RING	15-3266-51	1
31	PISTON BLOCK COVER	15-1561-20	1
32	P B COVER GASKET	15-3331-51	1
33	P B GASKET	15-3321-51	1
34	EXHAUST	15-1366-23	1
35	AIR NIPPLE	15-1371-07	1
36	5/16" X 1¾" HEX BOLTS SS (CHAMBER BOLTS SMALL)	04-6030-03	14
37	¼" X 3" ALLEN BOLTS MS (P B)	04-6003-61	4
38	5/16 X 20 X 2 MM SS WASHER	04-6216-03	34
39	5/16" X 1¼" HEX BOLTS SS (CHAMBER BOLTS BIG)	04-6028-03	10
40	5/16 MS HEX NUT	04-6305-61	10



AIR OPERATED DOUBLE DIAPHRAGM PUMPS



ISO 9001: 2008
ISO 14001: 2004

pricepumps.co.in

SECTION 3 – EXPLODED VIEW

1/2" POLYPROPYLENE PUMP

AOD 150/PKGP/SAN/TF/P/N

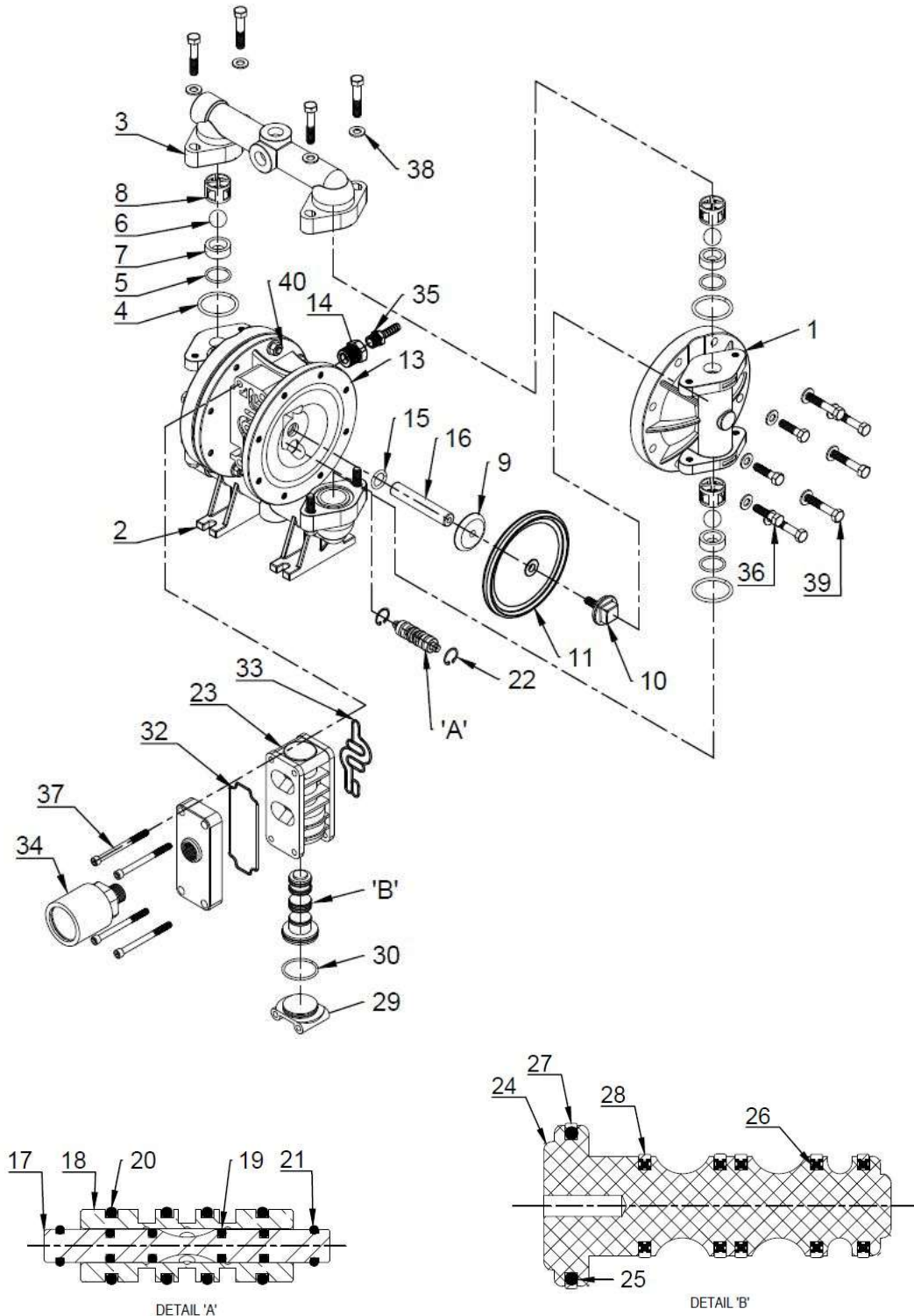



AIR OPERATED DOUBLE DIAPHRAGM PUMPS



ISO 9001: 2008
ISO 14001: 2004

pricepumps.co.in

SECTION 4 – DIMENSIONAL DRAWING

½" POLYPROPYLENE PUMP

AOD 150/PKGP/SAN/TF/P/N

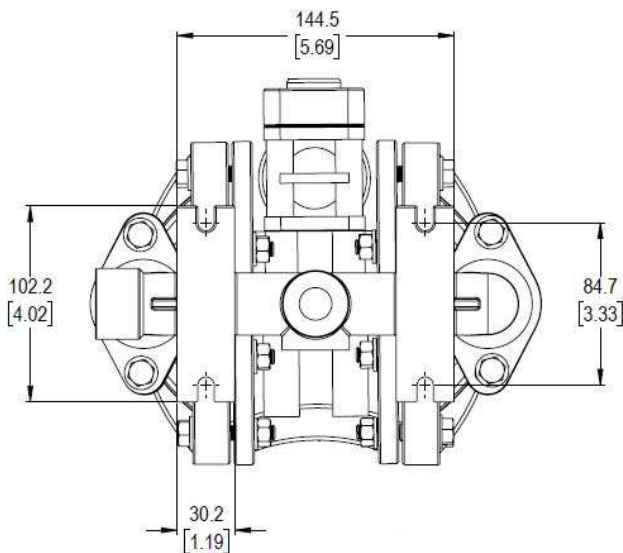
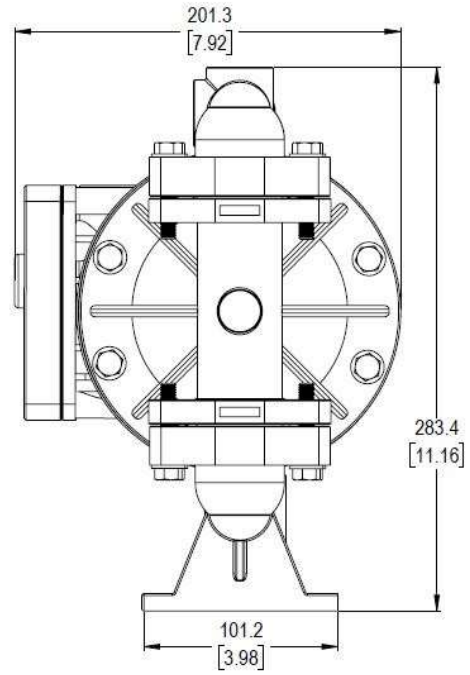
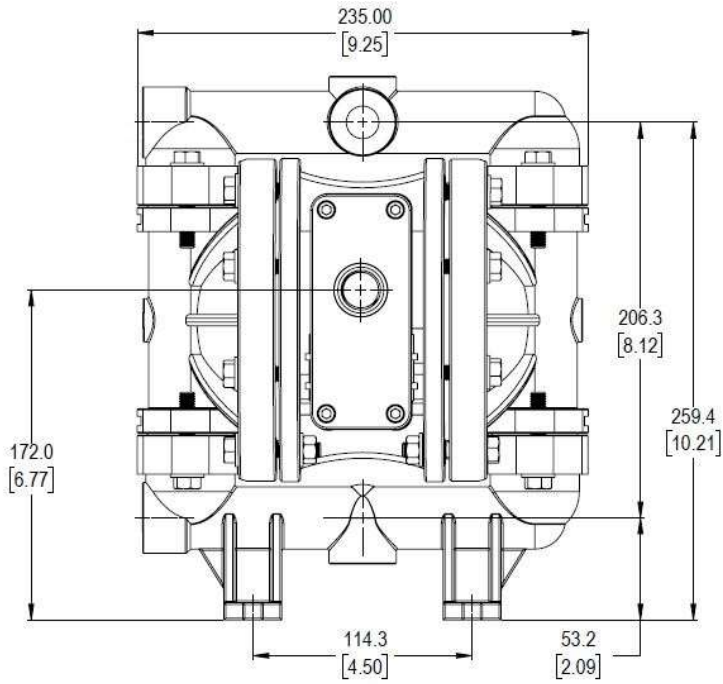



AIR OPERATED DOUBLE DIAPHRAGM PUMPS



ISO 9001: 2008
ISO 14001: 2004

pricepumps.co.in

SECTION 5 – SPECIFICATION & PERFORMANCE

½” POLYPROPYLENE PUMP

AOD 150/PKGP/SAN/TF/P/N

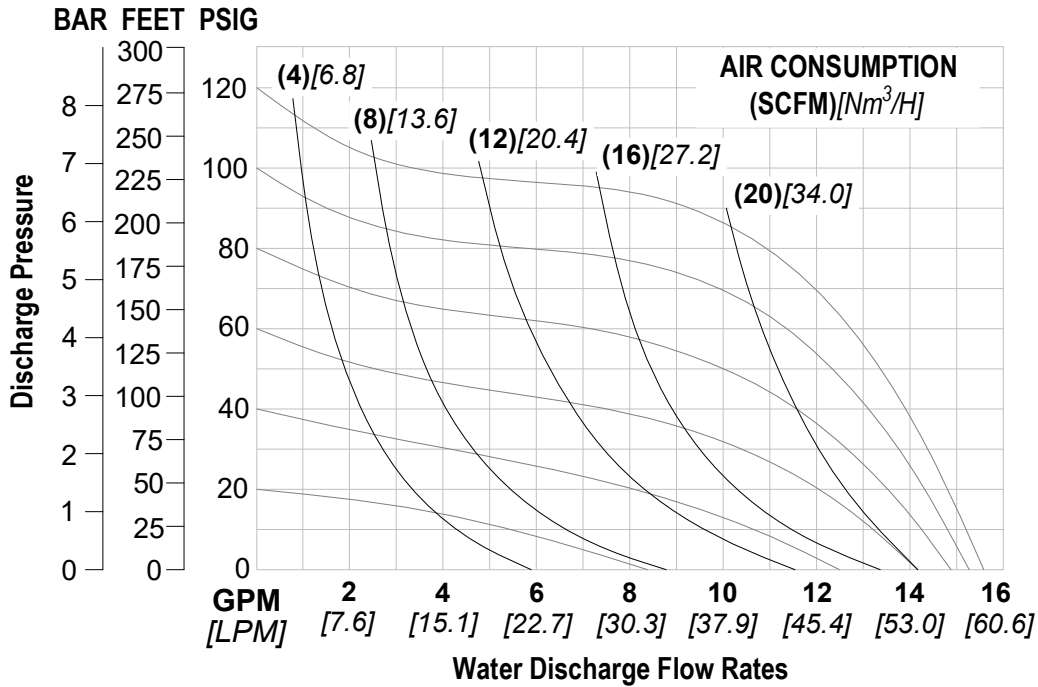

SPECIFICATIONS:

MAX FLOW RATE:	58.7 lpm (15.5 gpm)
MAX AIR PRESSURE:	120 psi (8.3 bar)
AIR INLET:	6 mm (1/4" BSP)
PORT INLET:	13 mm (1/2" BSP)
DISCHARGE:	13 mm (1/2" BSP)
SUCTION LIFT: DRY:	5.2 m (17.0')
WET:	8.7 m (28.4')
MAX PARTICLE SIZE:	(Dia) 1.6 mm (1/16")
AIR EXHAUST:	(1/2" BSP)

SHIPPING DIMENSIONS:

HEIGHT:	340 mm (13.38")
WIDTH:	240 mm (09.44")
LENGTH:	270 mm (10.63")
WEIGHT:	5.2 Kgs

Price Pumps meet ISO 9001-2015, ISO 14001 & CE quality standards.



**AIR OPERATED
DOUBLE
DIAPHRAGM
PUMPS**



ISO 9001: 2008
ISO 14001: 2004

pricepumps.co.in

NOTES: