



**AIR OPERATED
DOUBLE
DIAPHRAGM
PUMPS**



ISO 9001: 2008
ISO 14001: 2004

pricepumps.co.in

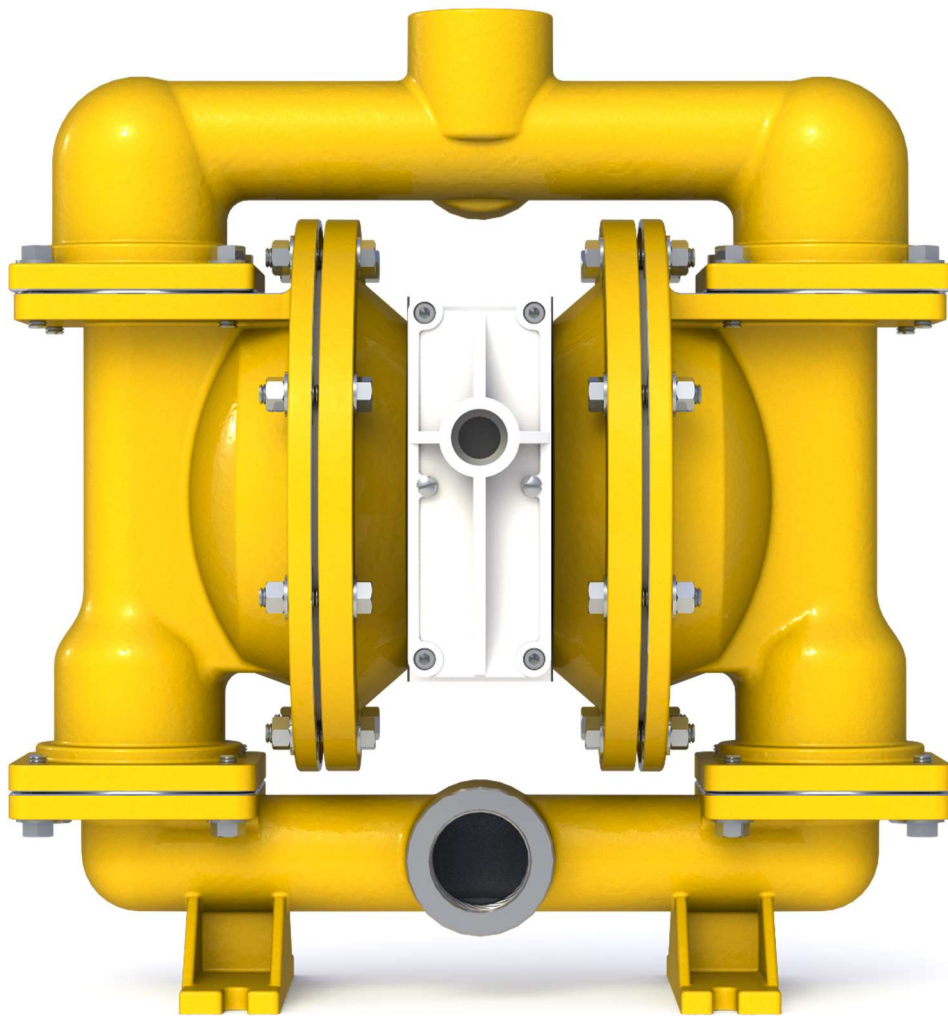

**1½" ALUMINIUM PUMP
AOD 400 PF ASGP/TEF/TF/S/T**

pricepumps.co.in



AIR OPERATED DOUBLE DIAPHRAGM PUMPS



ISO 9001: 2008
ISO 14001: 2004

pricepumps.co.in

SECTION 1- LEGEND

1½” ALUMINIUM PUMP

AOD 400/ASGP/TEF/TF/S/T

MODEL: AOD 400 PF ALUMINIUM

38mm (1½”) Pump

Maximum Flow Rate: 510 Lpm (135 gpm)

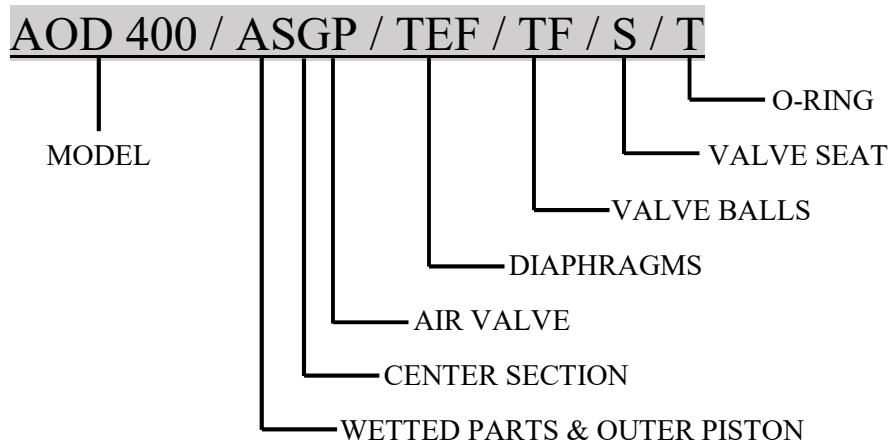

MATERIAL CODES

MODEL
AOD 400 = 1½” PUMP

AIR VALVE
P = POLYPROPYLENE

VALVE BALL
TF = TEFLON

WETTED PARTS & OUTER PISTON
AS = ALUMINIUM/
STAINLESS STEEL

DIAPHRAGMS
TEF = TEFLON

VALVE SEAT
S = STAINLESS STEEL

CENTER SECTION
G = GLASS FILLED
POLYPROPYLENE

VALVE SEAT O-RING
T = TEFLON



AIR OPERATED DOUBLE DIAPHRAGM PUMPS



ISO 9001: 2008
ISO 14001: 2004

pricepumps.co.in

SECTION 2 – SPARE PART LIST

1½” ALUMINIUM PUMP

AOD 400/ASGP/TEF/TF/S/T

SR No.	DISCRIPTION	PART No	QTY
1	LIQUID CHAMBER	40-1003-01	2
2	SUCTION MANIFOLD	40-1022-01	1
3	DISCHARGE MANIFOLD	40-1032-01	1
4	NRV BALL	40-1041-55	4
5	BALL SEAT	40-1072-01	4
6	SEAT O RING	40-3102-55	4
7	HOLDING PLATE	40-1111-61	2
8	LOCK NUT	40-1132-03	2
9	DIAPHRAGM	40-2001-55	2
10	BACK UP DIAPHRAGM	40-2101-65	2
11	CENTER BLOCK	40-1301-23	1
12	REDUCER	40-1376-21	1
13	CENTER BLOCK PATTI	40-1319-03	4
14	CENTER BLOCK PIPE	40-1318-03	4
15	CENTER BLOCK O RING	40-3155-56	4
16	MAIN SHAFT	40-1341-03	1
17	AIR COVER GASKET	40-3311-51	2
18	AIR COVER	40-1403-01	2
19	PILOT BUSH	40-1471-07	1
20	PILOT SHAFT	40-1451-03	1
21	PILOT BUSH O RING	40-3161-51	4
22	PILOT SHAFT O RING	15-3176-56	4
23	PILOT SHAFT LOCK O RING	40-3181-51	2



AIR OPERATED DOUBLE DIAPHRAGM PUMPS



ISO 9001: 2008
ISO 14001: 2004

pricepumps.co.in

SECTION 2 – SPARE PART LIST (CONTINUED...)

1½" ALUMINIUM PUMP

AOD 400/ASGP/TEF/TF/S/T

SR No.	DISCRIPTION	PART No	QTY
24	PISTON BLOCK	40-1501-20	1
25	PISTON	40-1521-69	1
26	PISTON/CAP O RING BIG	40-3201-51	2
27	PISTON O RING SMALL	40-3222-51	4
28	PISTON RING BIG	40-3241-68	1
29	PISTON RING SMALL	40-3246-68	4
30	PISTON BLOCK CAP	40-1571-20	1
31	PISTON BLOCK COVER	40-1561-20	1
32	PISTON BLOCK GASKET	40-3321-51	1
33	PISTON BLOCK COVER GASKET	40-3331-51	1
34	EXHAUST	40-1366-23	1
35	AIR NIPPLE	50-1371-07	1
36	3/8" X 1¾" HEX BOLTS SS (CHAMBER BOLT)	04-6018-03	16
37	3/8" X 1¼" HEX BOLTS SS (SUC/DIS)	04-6016-03	16
38	3/8" X 1¼" HEX BOLTS SS (AIR COVER)	04-6016-03	8
39	3/8 X 20.7 X 1.5 MM SS WASHER (CHAMBER)	04-6210-03	48
40	3/8 MS HEX NUT	04-6304-61	16
41	¼" X 4" ALLEN BOLTS MS (P B)	04-6005-61	4
42	P B SCREW MS	04-6321-61	2
43	3/8 X 3 MM SS WASHER (AIR COVER)	04-6206-03	8



AIR OPERATED DOUBLE DIAPHRAGM PUMPS



ISO 9001: 2008
ISO 14001: 2004

pricepumps.co.in

SECTION 3 – EXPLODED VIEW

1½" ALUMINIUM PUMP

AOD 400/ASGP/TEF/TF/S/T

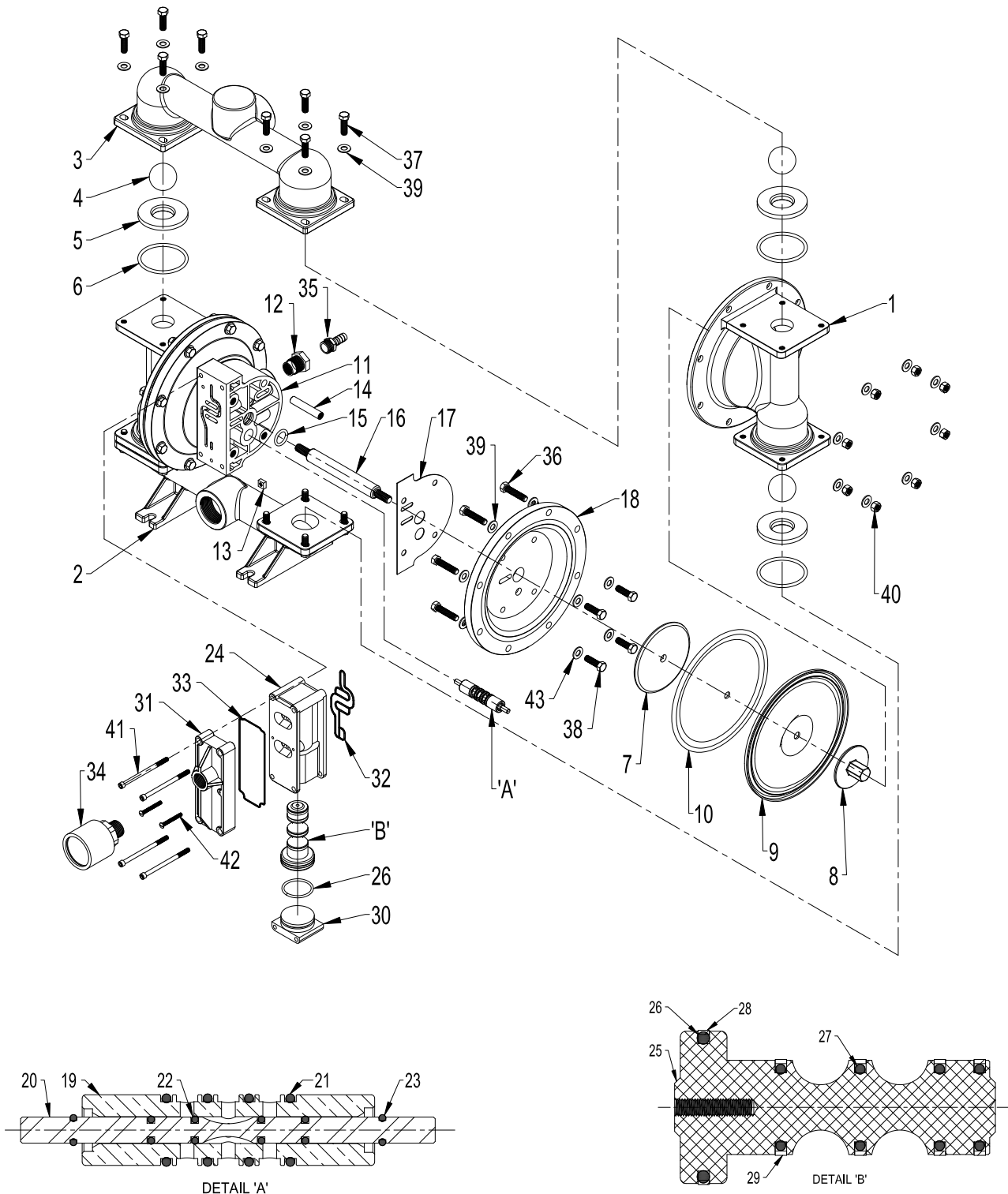



AIR OPERATED DOUBLE DIAPHRAGM PUMPS



ISO 9001: 2008
ISO 14001: 2004

pricepumps.co.in

SECTION 4 – DIMENSIONAL DRAWING

1½" ALUMINIUM PUMP

AOD 400/ASGP/TEF/TF/S/T

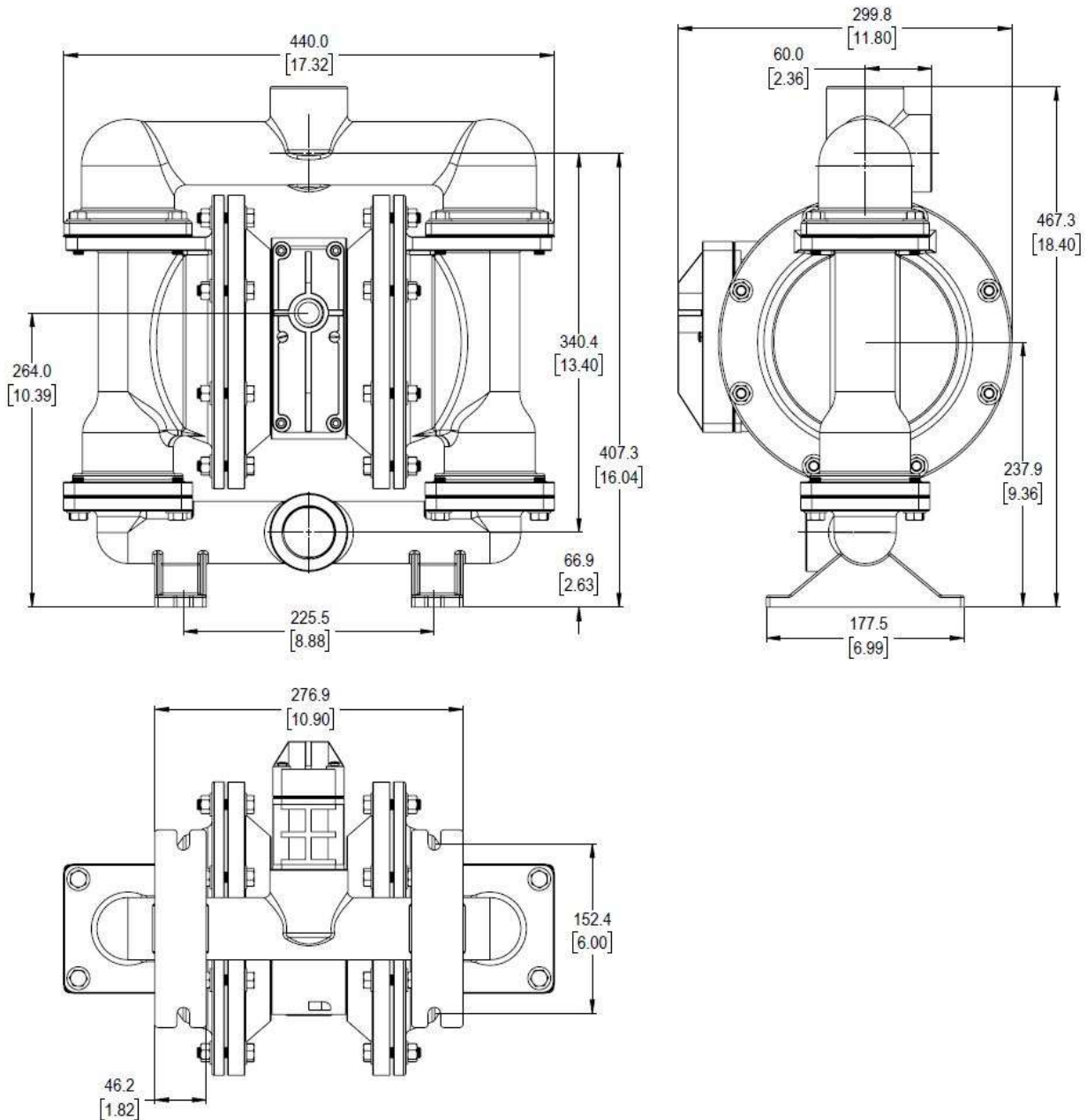



AIR OPERATED DOUBLE DIAPHRAGM PUMPS



ISO 9001: 2008
ISO 14001: 2004

pricepumps.co.in

SECTION 5 – SPECIFICATION & PERFORMANCE

1½” ALUMINIUM PUMP

AOD 400/ASGP/TEF/TF/S/T

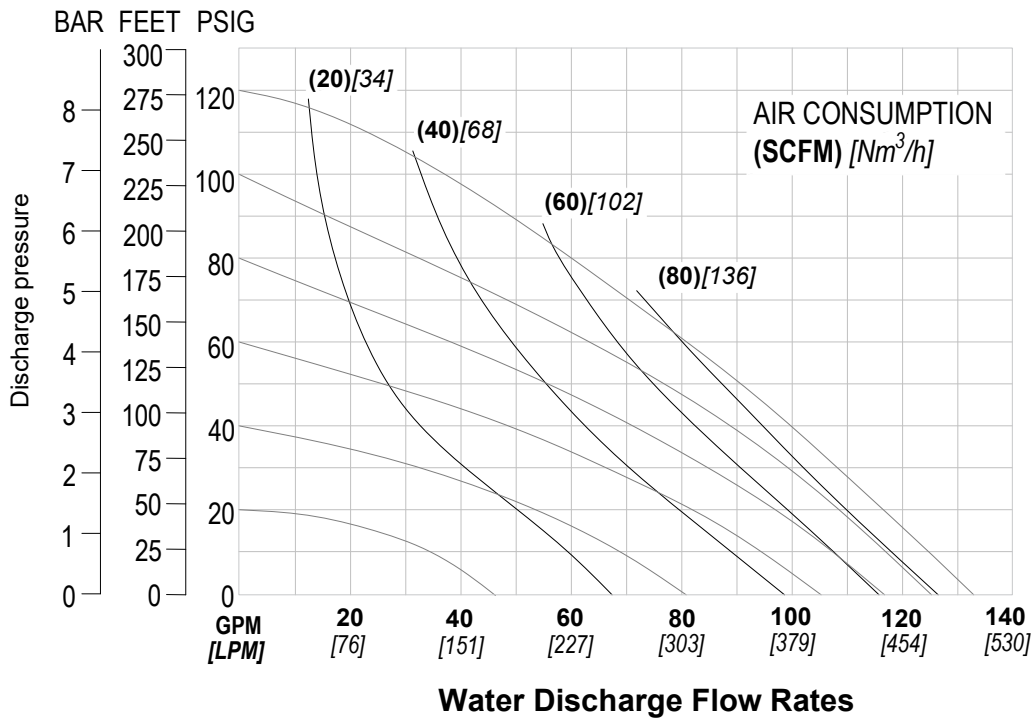

SPECIFICATIONS:

MAX FLOW RATE:	510 Lpm (135 gpm)
MAX AIR PRESSURE:	120 psi (8.3 bar)
AIR INLET:	13 mm (½” BSP)
PORT INLET:	38 mm (1½” BSP)
DISCHARGE:	38 mm (1½” BSP)
SUCTION LIFT: DRY:	5.9 m (19.5’)
WET:	9.0 m (29.5’)
MAX PARTICLE SIZE:	(Dia) 6.4 mm (1/4”)
AIR EXHAUST:	(¾” BSP)

SHIPPING DIMENSIONS:

HEIGHT:	540mm (21.26”)
WIDTH:	400mm (15.75”)
LENGTH:	450mm (17.72”)
WEIGHT:	31 Kgs

Price Pumps meet ISO 9001-2015, ISO 14001 & CE quality standards.



**AIR OPERATED
DOUBLE
DIAPHRAGM
PUMPS**



ISO 9001: 2008
ISO 14001: 2004

pricepumps.co.in

NOTES: