



**AIR OPERATED
DOUBLE
DIAPHRAGM
PUMPS**



ISO 9001: 2008
ISO 14001: 2004

pricepumps.co.in

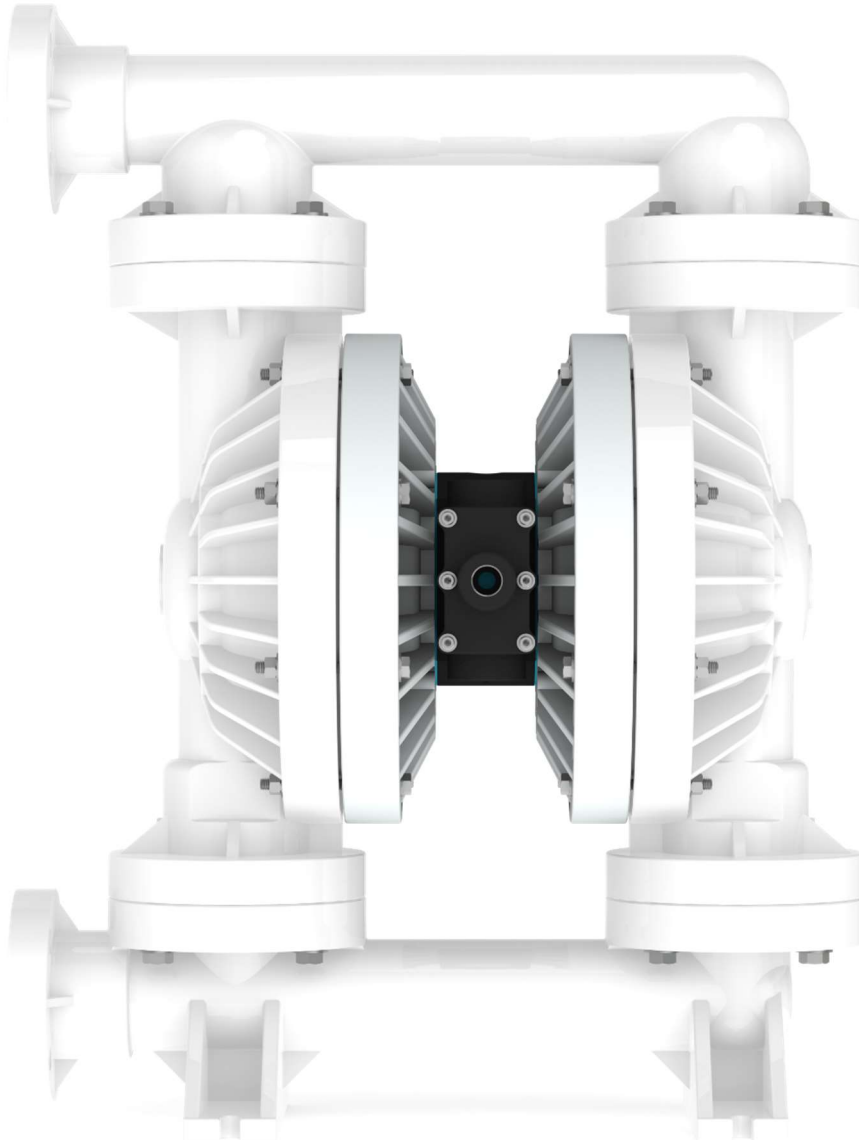

2" POLYPROPYLENE PUMP AOD 500 NSV PPGG/SAN/TF/P/T

pricepumps.co.in



AIR OPERATED DOUBLE DIAPHRAGM PUMPS



ISO 9001: 2008
ISO 14001: 2004

pricepumps.co.in

SECTION 1- LEGEND

2" POLYPROPYLENE PUMP

AOD 500/PPGG/SAN/TF/P/T

MODEL: AOD 500 NSV POLYPROPYLENE

51 mm (2") Pump

Maximum Flow Rate: 654 Lpm (173 gpm)

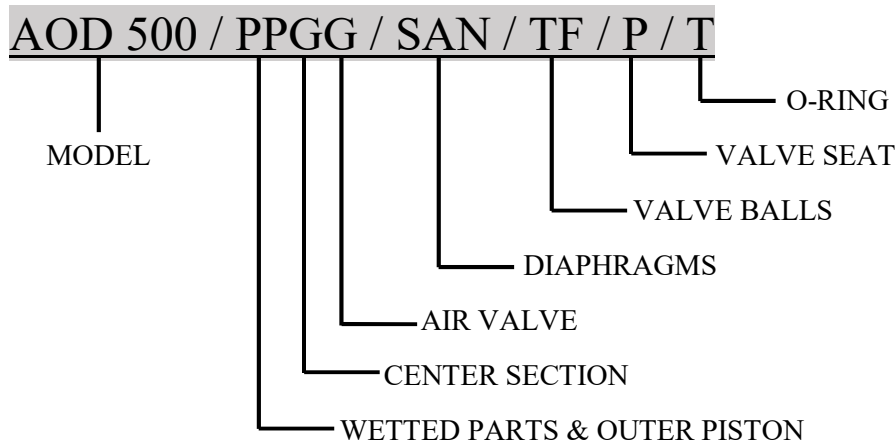

MATERIAL CODES

MODEL
AOD 500 = 2" PUMP

AIR VALVE
G = GLASS FILLED
POLYPROPYLENE

VALVE BALL
TF = TEFLON

WETTED PARTS & OUTER PISTON
PP = POLYPROPYLENE/
POLYPROPYLENE

DIAPHRAGMS
SAN = SANTOPRENE

VALVE SEAT
P = POLYPROPYLENE

CENTER SECTION
G = GLASS FILLED
POLYPROPYLENE

VALVE SEAT O-RING
T = TEFLON



AIR OPERATED DOUBLE DIAPHRAGM PUMPS



ISO 9001: 2008
ISO 14001: 2004

pricepumps.co.in

SECTION 2 – SPARE PART LIST

2” POLYPROPYLENE PUMP

AOD 500/PPGG/SAN/TF/P/T

SR No.	DISCRIPTION	PART No	QTY
1	LIQUID CHAMBER	50-1001-20	2
2	SUCTION MANIFOLD	50-1021-20	1
3	DISCHARGE MANIFOLD	50-1031-20	1
4	NRV BALL	50-1041-55	4
5	BALL SEAT	50-1061-20	4
6	BALL CAGE	50-1091-20	4
7	MANIFOLD O RING	50-3106-55	4
8	SEAT O RING	50-3111-55	4
9	HOLDING PLATE	50-1111-01	2
10	LOCK NUT	50-1132-20	2
11	DIAPHRAGM	50-2041-58	2
12	BACK UP DIAPHRAGM	N/A	-
13	CENTER BLOCK	50-1306-23	1
14	CENTER BLOCK O RING	40-3151-51	4
15	MAIN SHAFT	50-1342-03	1
16	AIR COVER	50-1405-23	2
17	AIR COVER BUFFER	40-1426-51	2
18	AIR COVER GASKET	50-3311-60	2
19	CENTER BLOCK PIPE	40-1316-03	4
20	PILOT SHAFT	50-1455-03	1
21	PILOT DRILL BUSH	40-1494-07	5
22	PILOT SHAFT O RING	40-3176-56	6
23	PILOT PLANE BUSH	40-1491-07	2



AIR OPERATED DOUBLE DIAPHRAGM PUMPS



ISO 9001: 2008
ISO 14001: 2004

pricepumps.co.in

SECTION 2 – SPARE PART LIST (CONTINUED...)

2" POLYPROPYLENE PUMP

AOD 500/PPGG/SAN/TF/P/T

SR No.	DISCRIPTION	PART No	QTY
24	PISTON BLOCK	50-1506-23	1
25	PISTON BLOCK BUSH	50-1541-07	1
26	PISTON BLOCK CAP/ PISTON BLOCK BUSH O RING	80-3271-51	8
27	PISTON	50-1525-01	1
28	PISTON O RING	50-3205-51	3
29	PISTON RING	50-3261-64	3
30	PISTON BLOCK CAP	50-1575-63	2
31	PISTON BLOCK CAP CIRCLIP	50-1581-61	2
32	PISTON BLOCK COVER	50-1564-23	1
33	PISTON BLOCK GASKET	50-3324-60	1
34	PISTON BLOCK COVER GASKET	50-3334-60	1
35	EXHAUST	40-1366-23	1
36	AIR NIPPLE	50-1371-07	1
37	3/8" X 110 MM HEX BOLTS SS (CHAMBER BOLTS)	04-6019-03	16
38	1/2" X 2" HEX BOLTS SS (SUC/DIS)	04-6009-03	16
39	5/16" X 1" HEX BOLTS SS (AIR COVER)	04-6027-03	10
40	3/8 X 30 X 3 MM MS WASHER (CHAMBER)	04-6213-61	32
41	1/2 X 32 X 3 MM MS WASHER (SUC/DIS)	04-6203-61	16
42	5/16 X 20 X 2 MM SS WASHER	04-6216-03	10
43	5/8 X 35 X 3 MM MS WASHER (HOLDING PLATE)	04-6217-61	2
44	3/8 MS HEX NUT	04-6304-61	16
45	1/4" X 4" ALLEN BOLTS MS (PISTON BLOCK)	04-6005-61	4
46	1/4 X 12.5 X 1.2 MM SS WASHER (P B ALLEN BOLT)	04-6202-03	4



AIR OPERATED DOUBLE DIAPHRAGM PUMPS



ISO 9001: 2008
ISO 14001: 2004

pricepumps.co.in

SECTION 3 – EXPLODED VIEW

2" POLYPROPYLENE PUMP

AOD 500/PPGG/SAN/TF/P/T

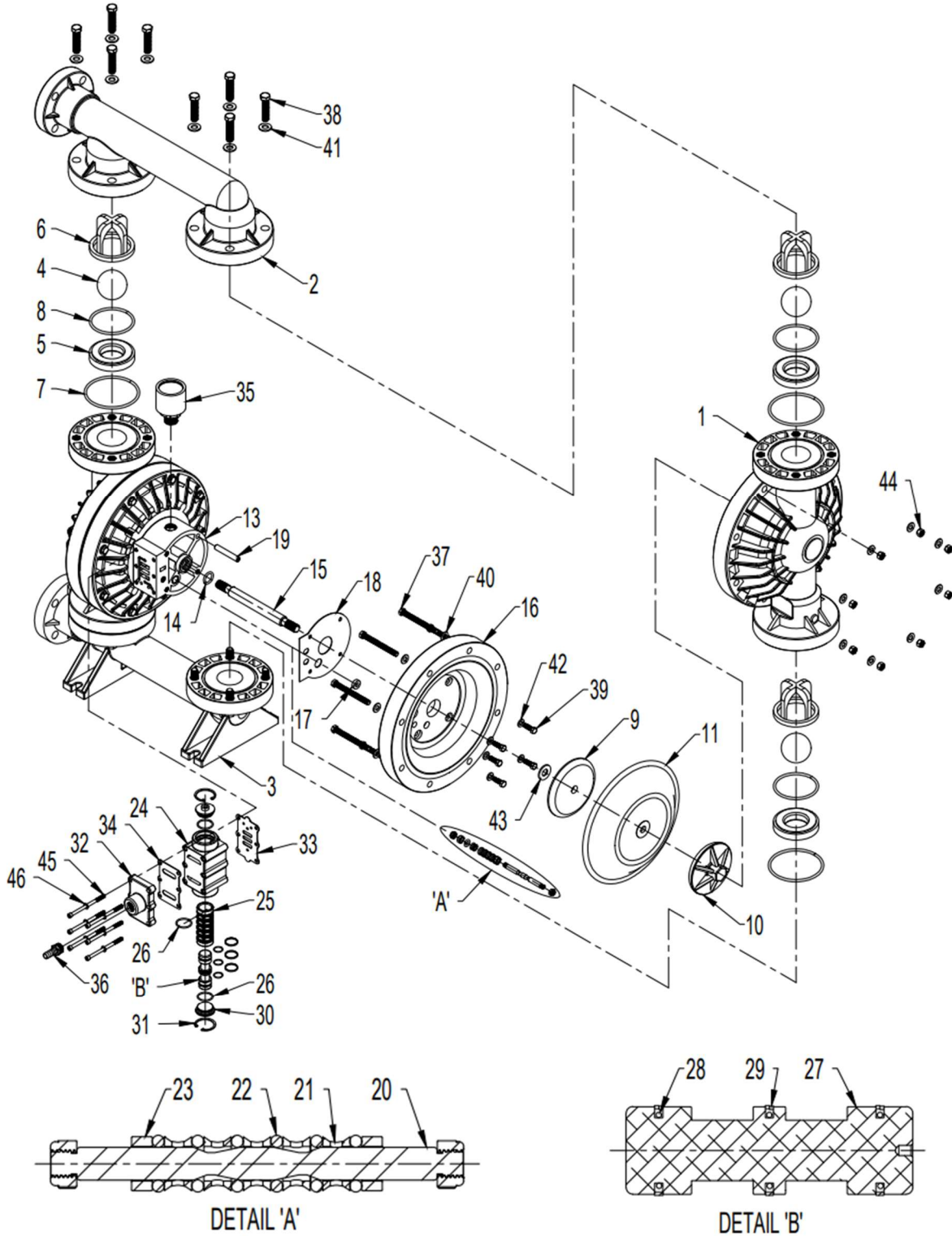



AIR OPERATED DOUBLE DIAPHRAGM PUMPS



ISO 9001: 2008
ISO 14001: 2004

pricepumps.co.in

SECTION 4 – DIMENSIONAL DRAWING

2" POLYPROPYLENE PUMP

AOD 500/PPGG/SAN/TF/P/T

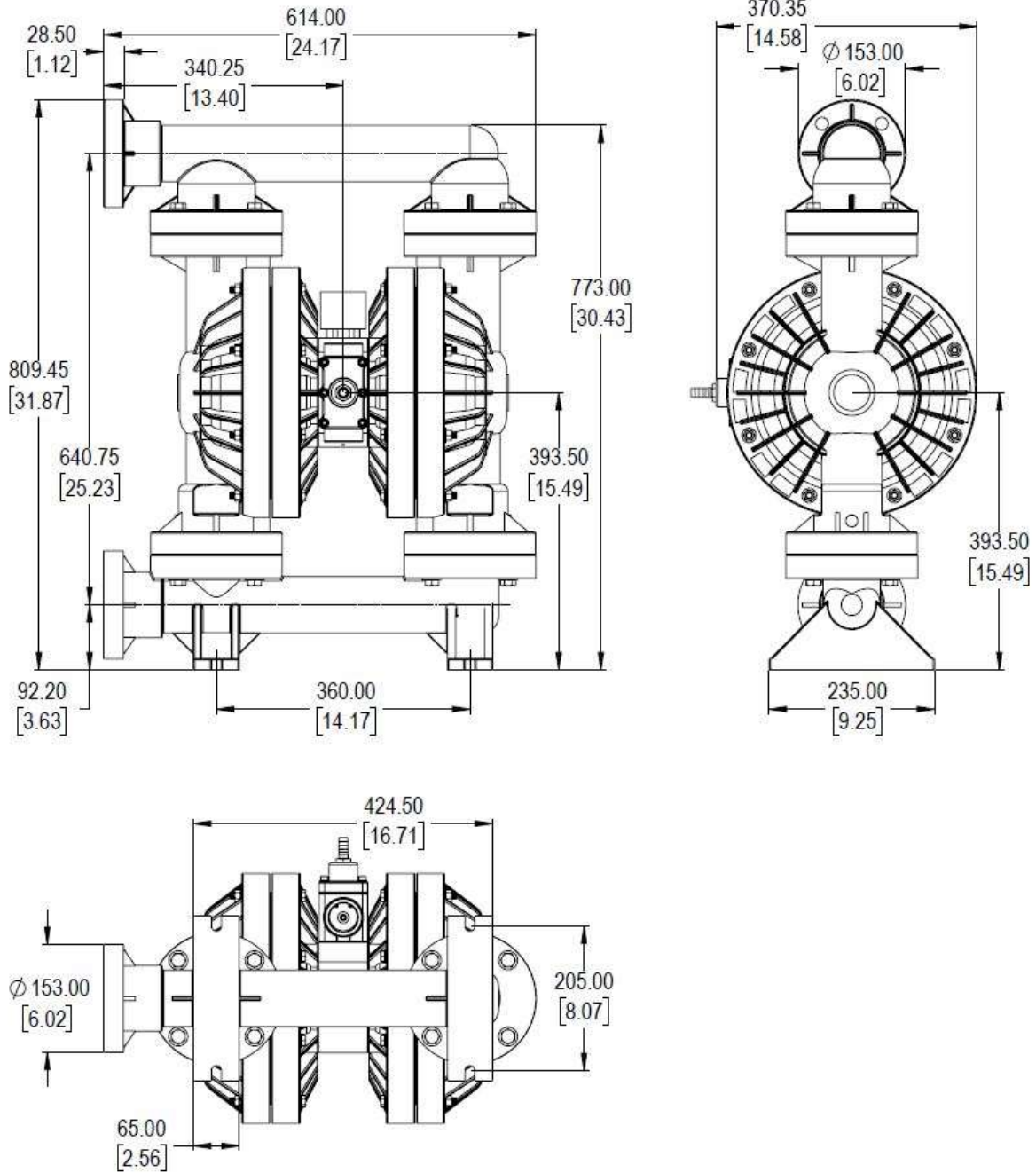



AIR OPERATED DOUBLE DIAPHRAGM PUMPS



ISO 9001: 2008
ISO 14001: 2004

pricepumps.co.in

SECTION 5 – SPECIFICATION & PERFORMANCE

2" POLYPROPYLENE PUMP

AOD 500/PPGG/SAN/TF/P/T

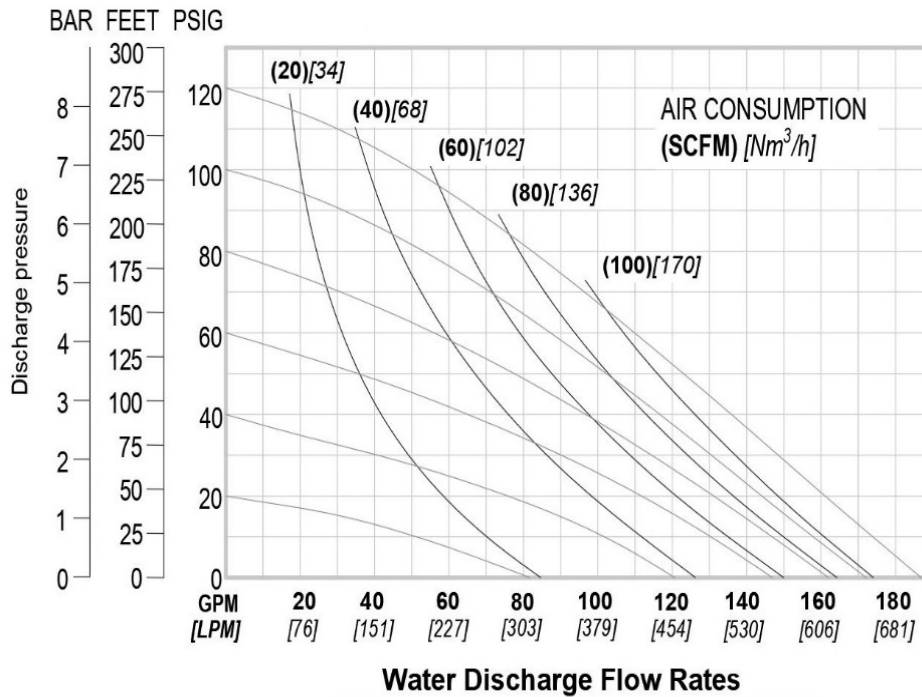

SPECIFICATIONS:

MAX FLOW RATE:	700 Lpm (185 gpm)
MAX AIR PRESSURE:	120 psi (8.3 bar)
AIR INLET:	13 mm (1/2" BSP)
PORT INLET:	51 mm (2" BSP)
DISCHARGE:	51 mm (2" BSP)
SUCTION LIFT: DRY:	5.9 m (19.5')
WET:	8.3 m (27.2')
MAX PARTICLE SIZE:	(Dia) 6.4 mm (1/4")
AIR EXHAUST:	(3/4" BSP)

SHIPPING DIMENSIONS:

HEIGHT:	860 mm (33.86")
WIDTH:	420 mm (16.53")
LENGTH:	660 mm (25.98")
WEIGHT:	39 Kgs

Price Pumps meet ISO 9001-2015, ISO 14001 & CE quality standards.



**AIR OPERATED
DOUBLE
DIAPHRAGM
PUMPS**



ISO 9001: 2008
ISO 14001: 2004

pricepumps.co.in

NOTES: